

Advanced transmission accessories for
ACCC[®] conductor

sicame
GROUP



About us

sicame
GROUP

Sicame Group is one of the key players in the electrical equipment business worldwide. It has been able to adapt and develop to support the continuous evolution of electricity infrastructure in France and around the world, and become the largest independent entity in its sector.

A true player in the energy transition, it offers its customers new products and services to improve energy efficiency, deal with environmental risks and support the development of electric vehicle and solar power plant markets.

+65

years of worldwide success

525 M€

2022 turnover

3,600

employees

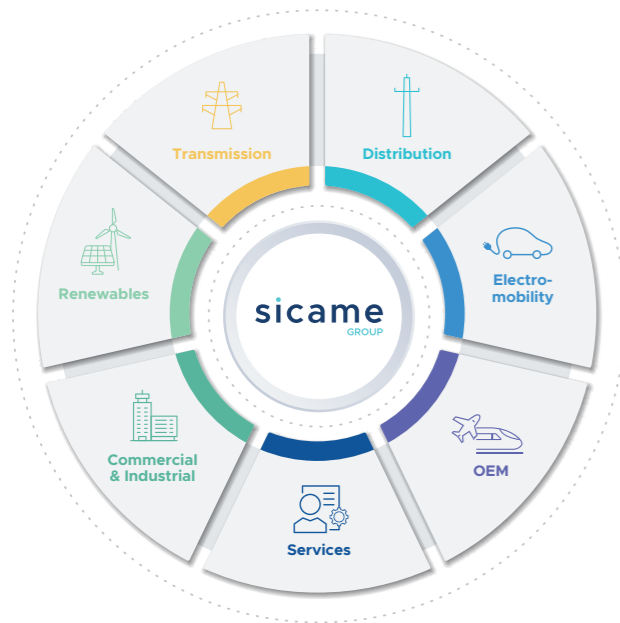

Our fields of activity

Sicame Group is specialised in **products and services** related to transmission and distribution of **electrical energy**, renewables, electromobility, safety equipment and industrial applications.

With decades of history and recognized expertise, our Transmission division is specialized in designing, manufacturing and producing comprehensive ranges of transmission lines and systems connectors, damping systems, hardware and most advanced substation fitting solutions, adapted to the most technical configurations such as 8-bundle spacer dampers, UHV HVDC connectors and innovative high temperature conductor's accessories.

5 continents

26 countries

50 companies
around the world

Products distributed
in **157** countries



HTLS



High temperature low sag cable line hardware

Since 2001, Dervaux has been working closely with the French electricity grid (RTE: Réseaux de Transport d'Electricité) and other major Utilities, to successfully qualify HTLS conductor sets and accessories.

Dervaux has confirmed for many years now, its strong technical capacity to design line hardware suitable to the HTLS conductors characteristics requirements:

- Maximum operating temperature (up to 250°C).
- Fully annealed aluminium for conductor strands.
- Gauges according to the required outputs.

We are qualified by most part of cable manufacturers either type of HTLS conductors, ACSS, Invar, Gap, carbon core and Metallic matrix type.

These specific conductor characteristics require the study and qualification of line hardware that result in safe, durable installations, whether new or existing lines.

This design results in good conductivity, good mechanical characteristics, and a low conductor sag.

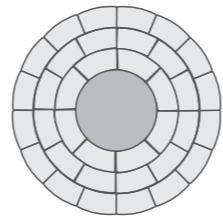
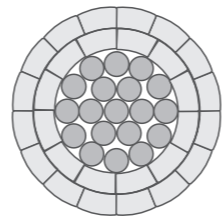
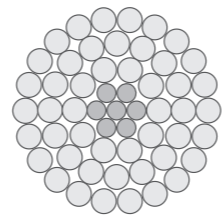
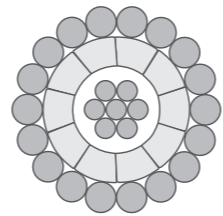
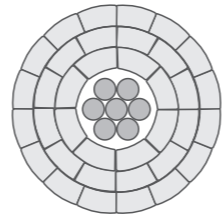
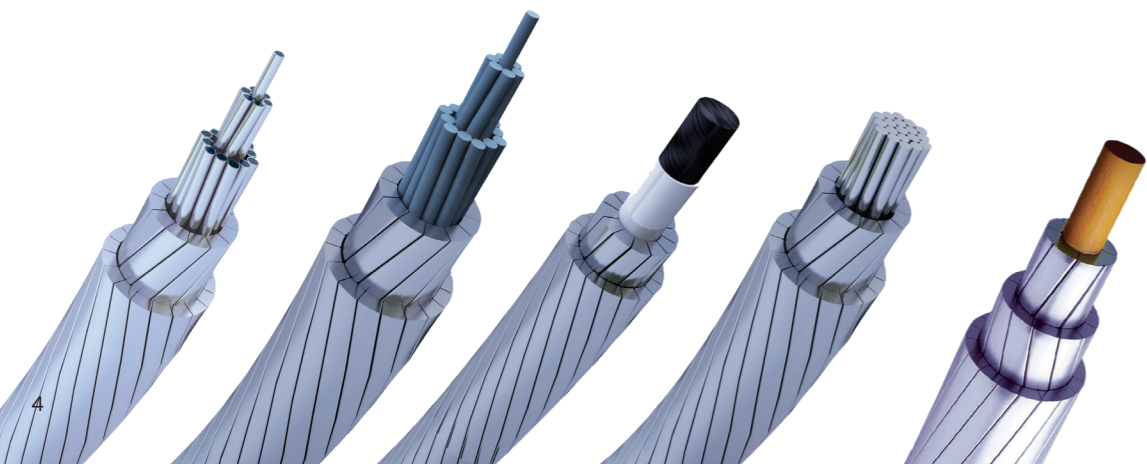

HTLS Accessories

Our offering includes a complete range of suspension, anchoring and connection accessories for poles.



Dead-end

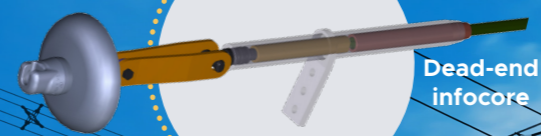

Dead-end infocore



Suspension clamps



Mid-span joint

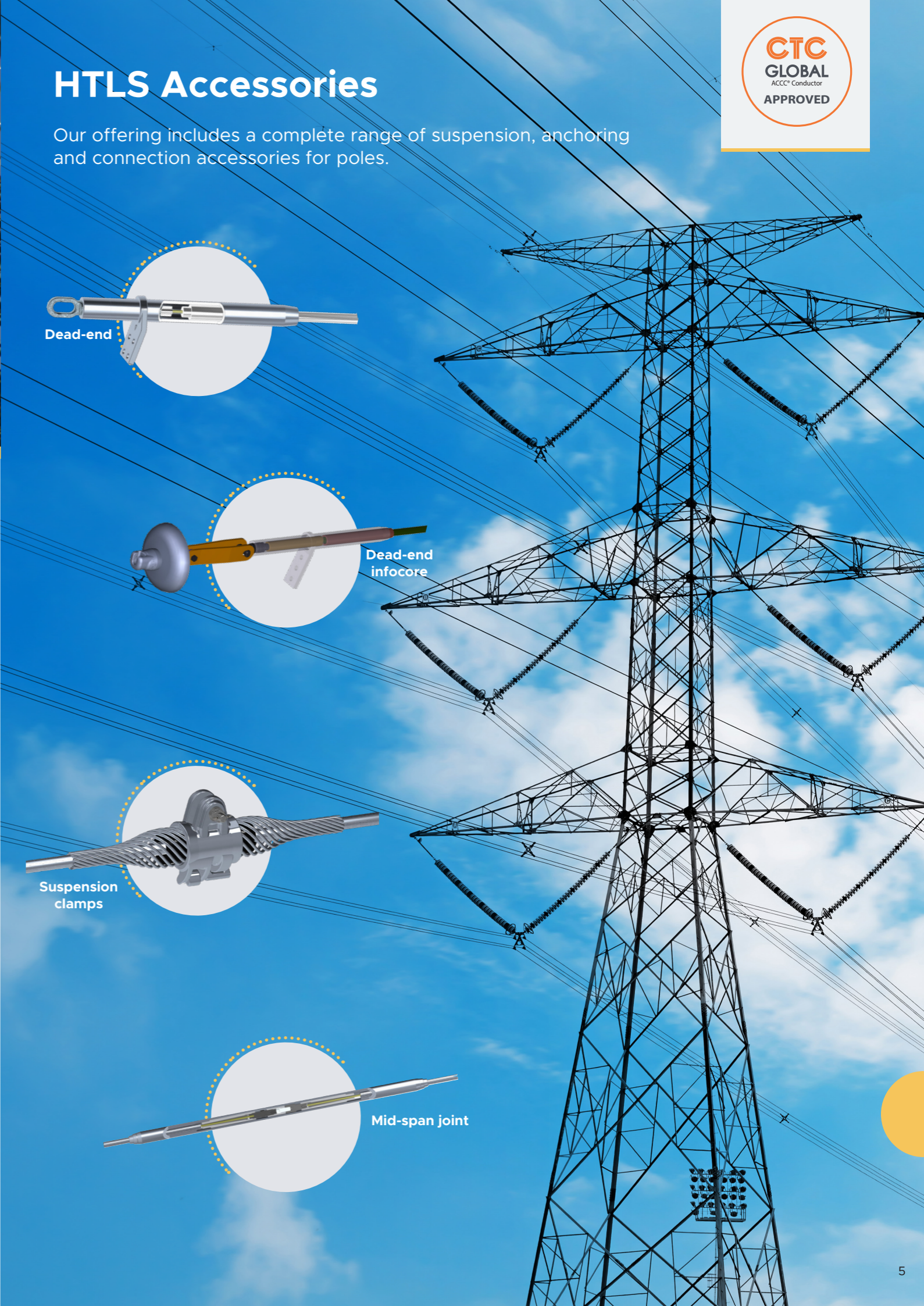

Damping science mastering



Spacer Dampers (SD)

The range of Sicame SD covers all possible applications:

- Voltage up to 1.200kV
- Bundle spacing up to 1.200mm
- Any conductor types
- Different clamping solutions



Vibration Dampers (VD)

In order to satisfy the demands of the market, our range of VD is very wide. It includes models with galvanized steel or zamaccoated masses and models with galvanized steel or stainless-steel messenger cable.

Specific information in terms of implementation or any question concerning the environment and conditions for using our solutions in your networks.



Sicame Group has vast experience on many overhead HTLS lines which have successfully been protected from vibration. We gained this experience, through advanced research projects including various partnerships with universities, scientific expertise using state of the art vibration simulation, damping techniques and including various elastomer materials.

Our expertise in R&D, design & test has and continues to assist engineers, consultants, and utilities globally, with new types of spacer dampers or vibration dampers for all types of conductor configurations.

Sicame Damping Systems Vibrations models induced by wind on single and bundle conductors which generate undesirable and dangerous phenomena on the OHTL:

- Aeolian vibration (Vortex Shedding)
- Wake induced oscillation (Sub-Span oscillation)
- Galloping

We developed the models which are linked to the tensile conductor loading and the particular evolution of self-damping linked to the use of the HTLS conductor.

Vibration level are controlled by Sicame using damping systems of spacer dampers and vibration dampers.

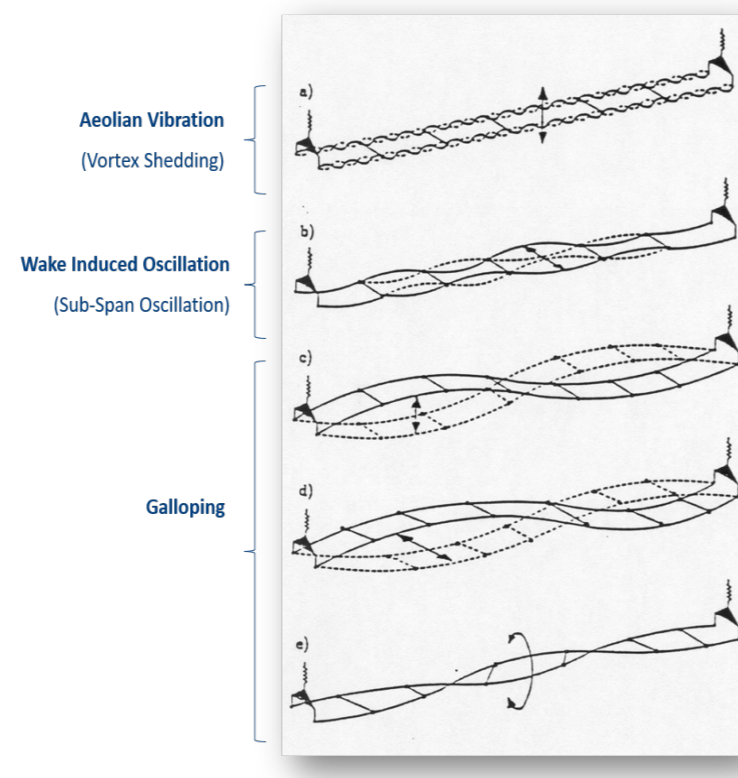

Analytical evaluation

Damping systems design

An optimum damping systems is designed to evaluate the two vibration phenomena (Aeolian vibration and Sub-Conductor oscillation) on the OHTL, by means of a damping study, performed with validated software, issued by a collaboration with Politecnico di Milano.

Due to thousands of hours of tests, we have acquired a good understanding of the dedicated self-damping profile linked to HTLS conductor and their different types.

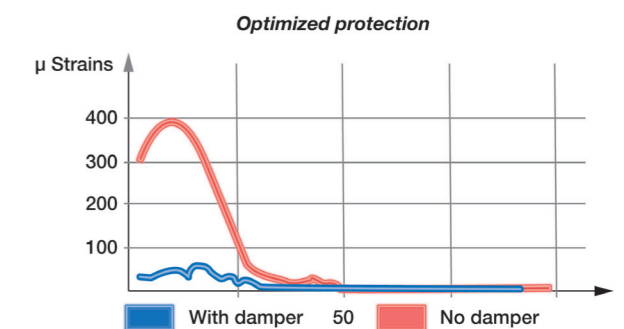

Damping systems validation

The validation of a damping system is carried out with measurements performed by Sicame equipment and personnel on the site ie (FIELD TEST). Such tests verify the real level of vibrations compared with evaluation at the design stage with the analytical method ie (DAMPING STUDY).

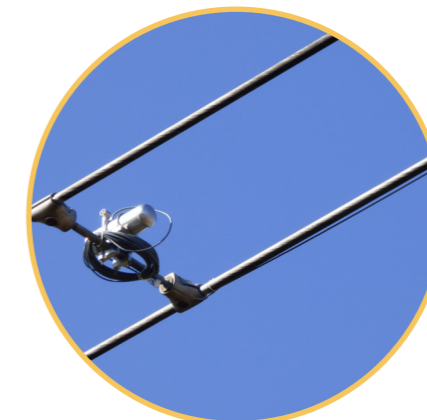

Laboratory testing & industrial manufacturing processes

High temperature low sag cable line hardware

Laboratories capabilities worldwide

- Certified laboratories
- State of art equipment
- 3rd party services
- Expertise
- University partnership



Tests and R&D

Our transmission laboratory is assisting both design activities and product verification. In the design stage it is supporting the technical department in its activity of research and development while in the product verification stage all quality control mechanical verifications and tests are carried out including batch acceptance tests.

We can perform also independent tests under accreditation or not for third party (cable manufacturers, utilities ...). Test bench systems have flexibility to meet specific requirements.

Components mechanical tests:

Are performed at our laboratories worldwide that are fully equipped for all kind of destructive and non-destructive tests.

Full scale mechanical tests:

We are also capable to carry out full scale mechanical tests in independent and accredited laboratories so as to verify the real mechanical behavior of the full strings.

Electrical tests on complete strings:

RIV and Corona, Power Arc and Short Circuit are carried out in independent laboratories according to international standards and prescriptions of project technical specifications.

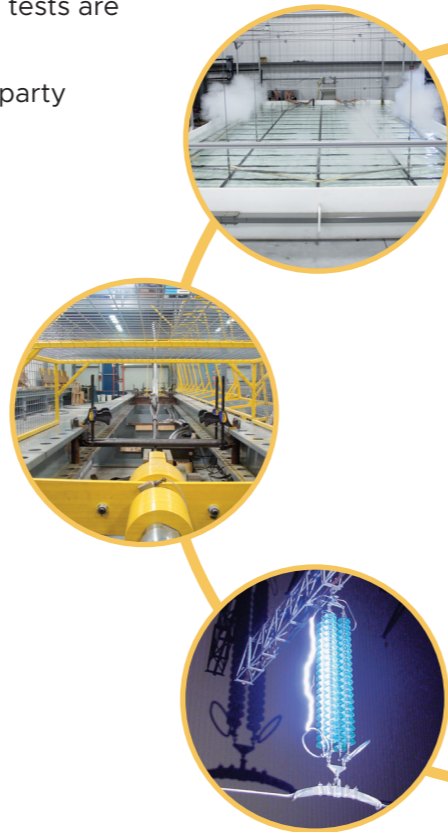

Manufacturing

Manufacturing activities are carried out in our factories directly or through our sub-suppliers and partners within Sicame Group.

- Manufacturing processes excellence centers.
- Interconnected supply chain among business unit net work.
- Complete manufacturing processes inside business unit.



Mechanical and electrical tests



Category	Equipment	Tests	Standards
Tensile tests	800 kN tensile test bench. Length: 21m Program with stress and displacement instructions	Tensile tests on dead end and midspan joint	IEC 61284
		Mechanical fatigue test	IEC 61284
		Vertical tests on suspension clamp	IEC 61284
		Stress train tests	EN 50182
Slip tests	800 kN tensile test bench. Length: 21m Program with stress and displacement instructions	On suspension clamp	IEC 61284
		On vibration dampers	IEC 61897
		On spacer dampers	IEC 61854
Creep test	Experimental span of 20m to 50m Ambient temperature regulation system: max.0.2°C/hour Thermal sensor, laser displacement sensor, loadsensor	Mechanical fatigue test	IEC 61854

Electrical tests

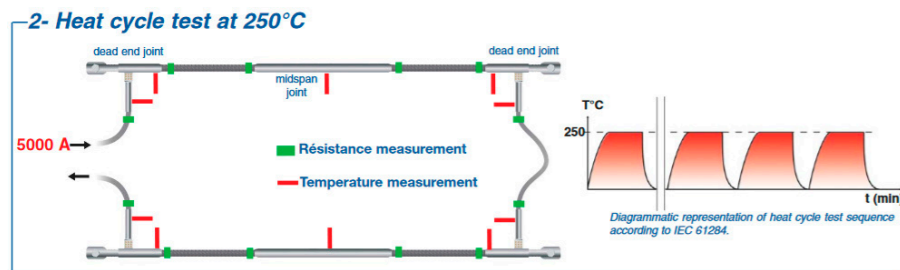

Category	Equipment	Tests	Standards
Heat cycle	Generator; 6000A-40V; 21 thermalsensors Generator; 3000A-40V; 21 thermalsensor	Dead end, mid span joint, jumperterminal, connectors	IEC 61284
High Voltage	HV generator up to 250 kV phase-ground (equivalent to 430 kV phase to phase)	On suspension clamp	IEC 61284
Simulated short circuit	Test bench for spacers (x2, x3, x4)	Compression and tension	IEC 61284

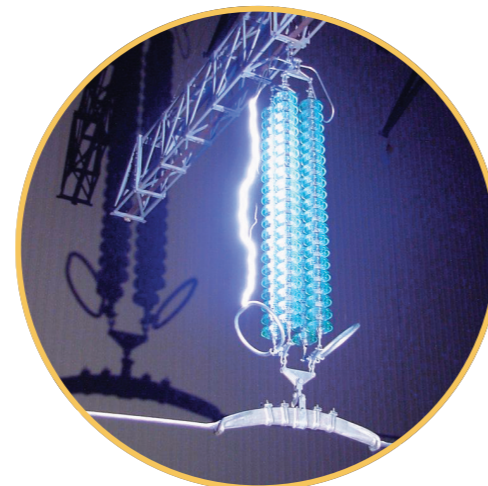

Combined mechanical and electrical tests

Category	Equipment	Tests	Standards
Heat cycle	800kN tensile tests bench, Current generator 50Hz; 6000A-40V; 21 thermal sensors	High temperature tensile test	IEC 61284
High Voltage	800kN tensile tests bench, Current generator 50Hz; 6000A-40V; 21 thermal sensors. Thermocouples, laser displacement sensor, load sensor	CTE on all conductors	CIGRE TB426
Simulated short circuit	Slipping test area. Length: 20m Regulated tensile machine, sensor: 250kN, 200kN, 50kN Current generator 50Hz; 6000A-40V; 21 thermal sensors	Slip tests on all conductors	IEC 61854

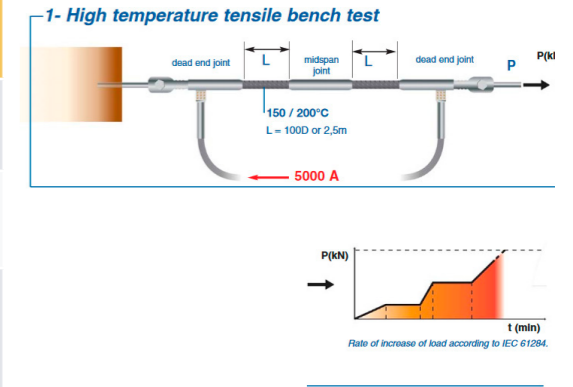

Vibratory tests

Category	Equipment	Tests	Standards
Self damping test	Span length: 51m. Force excitation with shakers. Regulated room temperature Minimum energy dissipation at ends	On conductor	IEC 62567
Damping effectiveness	Span length: 51m. Force excitation with shakers. Regulated room temperature Strain and antinode measurement methods	On spacers / vibration dampers, jumpers, spiral.	IEC 61897
Fatigue test	Span length: 51m or 2 spans of 30m (crossing length). Force excitation with shakers. Can be performed with high temperature and tension	Span fatigue, suspension clamp.	IEC 62568
	Shaker and 50 span	On vibration dampers, -different methods : sweep, resonance R4 and 4 resonances	IEC 61897
	Dedicated test bench and Shaker	On spacers dampers, sub-spanoscillation, aeolian vibration, conical and horizontal fatigue	IEC 61854
Environmental test	Shakers	Sweep ageing	IEC 60068

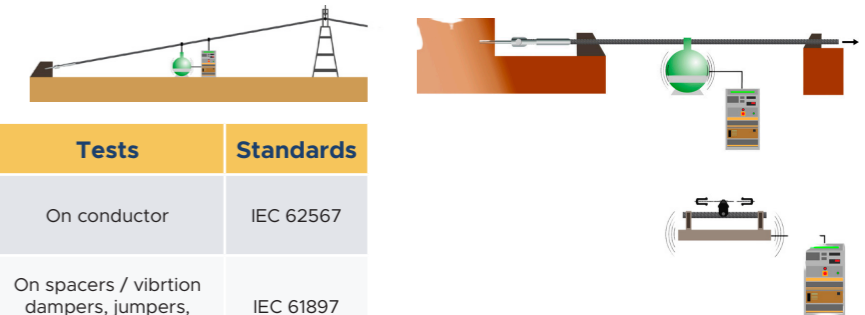

Others tests

Category	Equipment	Tests	Standards
Salt spray	Combo climatic chamber: T° range -60°C to +180°C Coupling with shaker Dry & wet heat	Corrosion test on every type of fittings	ISO 9227-2007

Full-Scale Mechanical Tests:

We are also capable of carrying out full-scale mechanical tests independent and accredited laboratories to verify the actual mechanical behaviour of the full strings.

Electrical tests on complete strings:

RIV and Corona, Power Arc and Short Circuit are conducted out independent and accredited laboratories according to International Standards and prescriptions of project technical specifications.



ACCC[®] Conductor benefits

Fastest and most cost-effective way to increase line capacity

Reconductoring reduces permitting challenges and the need to replace existing structures, which saves time and money. The ACCC[®] Conductor can carry twice the current capacity and reduces line loss by ~30% compared to conventional ACSR conductors. Reconductoring rapidly provides substantial power line capacity increase at the lowest cost.

Achieve sustainability and decarbonization goals

The ACCC[®] Conductor is the most energy efficient conductor on the market today. Its lighter weight composite core enables the use of nearly ~30% more aluminum. The added aluminum content reduces electrical resistance and line losses by ~30%. Reduced line loss reduces fuel consumption and associated emissions while freeing up generation capacity otherwise wasted. Use of ACCC[®] Conductor is helping reduce GHG emissions, globally, at an impressive rate.

Improve reliability & resilience

The ACCC[®] Conductor's high-capacity, high-strength, low-sag, and resistance to corrosion and fatigue performance are proven to increase grid reliability and resilience. Reduced sag reduces the likelihood of sagtrip outages and wildfires. High capacity can allow grid operators to reroute power through ACCC[®] Conductors during emergency conditions, and the composite core is so strong, it has survived direct strikes from tornado debris and hurricane force winds.



Compression fitting for ACCC[®] Conductors

Sicame fittings have been specifically designed for CTC's ACCC[®] Conductors. Each fitting is designed and manufactured in France. The raw material use guarantees the right transfer of the maximum rated current and the efficient dissipation of the increased heat allowed by the ACCC[®] conductor.

All Sicame compression fittings are designed for full tension use, performing a minimum of 95% of the UTS of the ACCC[®] Conductor. All family range dead ends can be supplied with eye bolt or tongue or clevis arrangement depending on requirements. Compression fittings are delivered with grease with a melt point > 300°C.

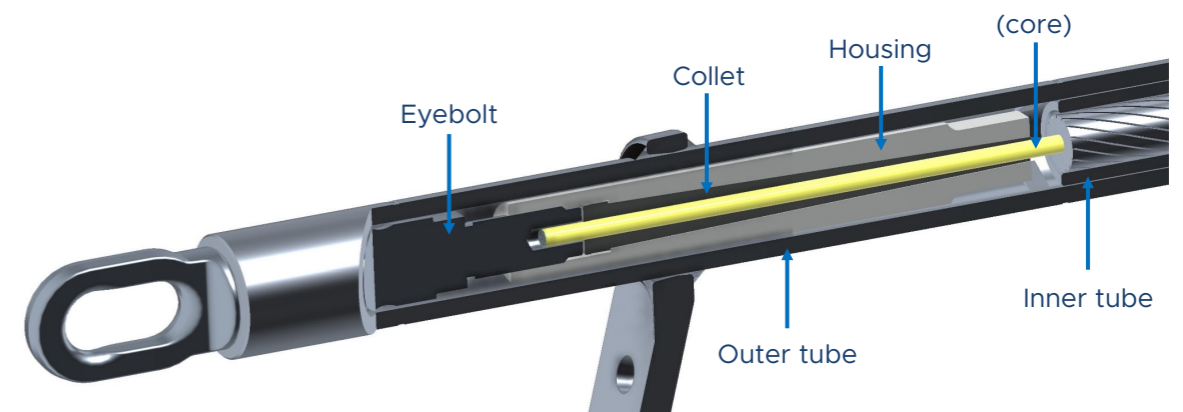

Sicame dead end pad and terminal connector pad are designed in accordance with standards: IEC 61284 with a 15° angle, which allows the terminal connector to be bolted on the straight or 30° position.



Dead-end clamp

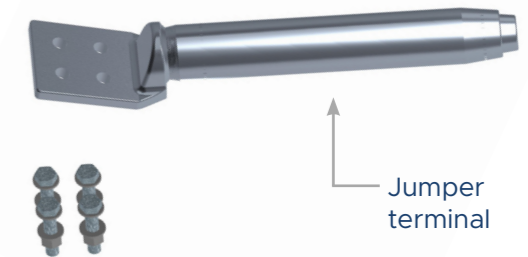

Jumper terminal

Sicame midspan joint is designed in accordance to standards: IEC 61284.

Sicame HTLS knowledge and expertise have allowed to design a midspan joint shorter than the competition which will be faster to crimp on site.

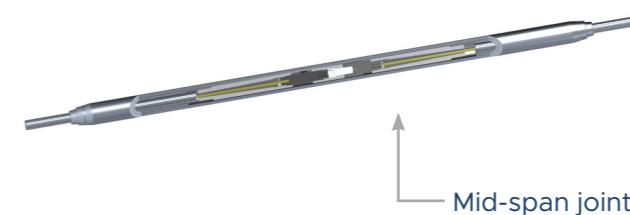

Mid-span joint

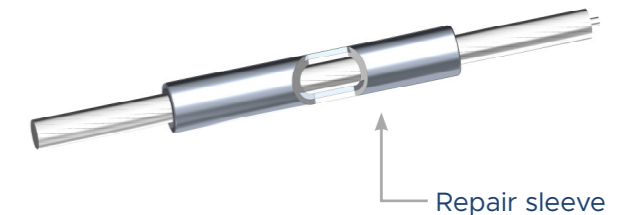

Repair sleeve

Suspension clamp & vibration damper

Suspension clamp

The armor grip design gives soft retention of the conductor without an inflection point, to avoid vibration fatigue, and stress on carbon core. Armor rod sets reduce the local temperature of a conductor by decreasing the joule effect and increasing the thermal dissipation.

The lining of the suspension clamps have been specially designed and tested to guarantee the protection of the conductor in contact with the suspension clamp, by integrating the constraints of the external environment (UV, bad weather, etc.) associated with the high operating temperature requirements of the ACCC® cable.

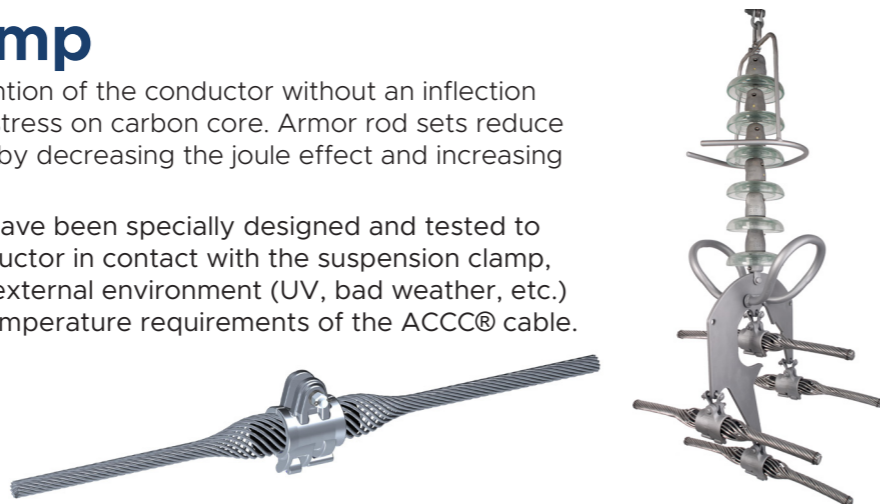

Vibration damper

Installed on armor rod sets to protect the soft aluminum and reduce the local temperature of the conductor. 4 frequency response for larger damping spectrum. Dedicated clamp/attachment design to use on armor rod set. Space dampers can also be supplied in case of multiple bundles.



ACCC® Conductor accessories

International sizes	ACCC® Size	Diameter		Core Diameter		Dead end	Mid-Span Joint	Jumper terminal	Repair Sleeve	Suspension Clamp	Stockbridge Damper + Armor rod
		(mm)	(Inch)	(mm)	(Inch)						
SILVASSA	-	14,35	0,565	5,97	0,235	V2NFK	JCTCFK	CDAXFK	R150K	SAR 137-166	STLJC + AAR140
HELSINKI	-	15,65	0,616	5,97	0,235	V2NFK	JCTCFK	CDAXFK	R170K	SAR 137-166	STNJC + AAR154
JAIPUR	-	16,50	0,650	7,75	0,305	V2NFK	JCTCFK	CDAXFK	R185K	SAR 166-199	STNJC + AAR164
ZADAR	-	17,10	0,673	7,11	0,280	V2NFK	JCTCFK	CDAXFK	R185K	SAR 166-199	STNJC + AAR166
ROVINJ	-	17,10	0,673	5,97	0,235	V2NFK	JCTCFK	CDAXFK	R185K	SAR 166-199	STNJC + AAR166
-	OCEAN SIDE	17,27	0,680	5,97	0,235	V2NFK	JCTCFK	CDAXFK	R185K	SAR 166-199	STNJC + AAR166
COPENHAGEN	LINNET	18,29	0,720	5,97	0,235	V2NFK	JCTCFK	CDAXFK	R210K	SAR 166-199	STNL + AAR178
REYKJAVIK	ORIOLE	18,82	0,741	7,11	0,280	V2NFK	JCTCFK	CDAXFK	R210K	SAR 166-199	STNL + AAR188
GDANSK	-	19,20	0,756	5,97	0,235	V2NFK	JCTCFK	CDAXFK	R210K	SAR 166-199	STNL + AAR188
GLASGOW	WACO	19,56	0,770	7,75	0,305	V2NFK	JCTCFK	CDAXFK	R210K	SAR 166-199	STNL + AAR195
MONTE CARLO	-	20,78	0,818	10,54	0,415	V2NFK	JCTCFK	CDAXFK	R235K	SAR 200-258	STPL + AAR206
CASABLANCA	LAREDO	20,50	0,807	7,11	0,280	V2NFK	JCTCFK	CDAXFK	R235K	SAR 200-258	STPL + AAR200
OSLO	IRVING	22,40	0,882	8,76	0,345	V2NFK	JCTCFK	CDAXFK	R235K	SAR 200-258	STPL + AAR219
LISBON	HAWK	21,79	0,858	7,11	0,280	V2NFK	JCTCFK	CDAXFK	R235K	SAR 200-258	STPL + AAR219
AMSTERDAM	DOVE	23,55	0,927	7,75	0,305	V2NFK	JCTCFK	CDAXFK	R255K	SAR 200-258	STPL + AAR230
VANCOUVER	-	25,00	0,984	10,54	0,415	V2NFK	JCTCFK	CDAXFK	R280K	SAR 200-258	STPN + AAR248
CORDOBA	-	24,41	0,961	7,75	0,305	V2NFK	JCTCFK	CDAXFK	R280K	SAR 200-258	STPL + AAR240
LEIPZIG	-	25,14	0,990	9,53	0,375	V2NFK	JCTCFK	CDAXFK	R280K	SAR 200-258	STPN + AAR248
BRUSSELS	GROSBEAK	25,15	0,990	8,13	0,320	V2NFK	JCTCFK	CDAXFK	R280K	SAR 200-258	STPN + AAR248
STOCKHOLM 3L	-	26,40	1,039	8,76	0,345	T2NFK	JCTCFK	CDAXFK	R280K	SAR 258-307	STPN + AAR263
STOCKHOLM 2L	LUBBOCK	26,40	1,039	8,76	0,345	T2NFK	JCTCFK	CDAXFK	R280K	SAR 258-307	STPN + AAR263
WARSAW	GALVESTON	27,72	1,091	8,76	0,345	T2NFK	JCTCFK	CDAXFK	R301K	SAR 258-307	STUN + AAR270
DUBLIN	DRAKE	28,14	1,108	9,53	0,375	T2NFK	JCTCFK	CDAXFK	R323K	SAR 258-307	STUN + AAR279
KOLKATA	-	28,62	1,127	9,53	0,375	T2NFK	JCTCFK	CDAXFK	R323K	SAR 258-307	STUN + AAR279
-	CURLEW	28,96	1,140	10,54	0,415	T2NFK	JCTCFK	CDAXFK	R323K	SAR 258-307	STUN + AAR279
MAHAKAM	-	29,00	1,142	10,54	0,415	T2NFK	JCTCFK	CDAXFK	R323K	SAR 258-307	STUN + AAR280
HAMBURG	PLANO	28,62	1,127	8,76	0,345	T2NFK	JCTCFK	CDAXFK	R323K	SAR 258-307	STUN + AAR279
MILAN	CORPUS CHRISTI	29,10	1,146	8,76	0,345	T2NFK	JCTCFK	CDAXFK	R323K	SAR 258-307	STUN + AAR289
ROME	ARLINGTON	29,89	1,177	9,53	0,375	T2NFK	JCTCFK	CDAXFK	R323K	SAR 258-307	STUN + AAR295
VIENNA	CARDINAL	30,42	1,198	8,76	0,345	T2NFK	JCTCFK	CDAXFK	R323K	SAR 258-307	STUN + AAR301
BUDAPEST	FORT WORTH	31,50	1,240	9,53	0,375	T2NFK	JCTCFK	CDAXFK	R350K	SAR 307-343	STUN + AAR312
MUMBAI	-	31,77	1,251	9,53	0,375	T2NFK	JCTCFK	CDAXFK	R350K	SAR 307-343	STUN + AAR312
PRAGUE	EL PASO	31,77	1,251	8,76	0,345	T2NFK	JCTCFK	CDAXFK	R350K	SAR 307-343	STUN + AAR312
DHAKA	-	32,87	1,294	9,53	0,375	T2NFK	JCTCFK	CDAXFK	R350K	SAR 307-343	STUN + AAR327
MUNICH	BEAUMONT	32,85	1,293	9,53	0,375	T2NFK	JCTCFK	CDAXFK	R350K	SAR 307-343	STUN + AAR327
WARWICK	-	33,40	1,315	10,54	0,415	T2NFK	JCTCFK	CDAXFK	R390K	SAR 307-343	STUP + AAR334
LONDON	SAN ANTONIO	33,40	1,315	9,78	0,385	T2NFK	JCTCFK	CDAXFK	R390K	SAR 307-343	STUP + AAR334
PARIS	BITTERN	34,16	1,345	8,76	0,345	T2NFK	JCTCFK	CDAXFK	R390K	SAR 307-343	STUP+ AAR334
BORDEAUX	-	35,76	1,408	10,54	0,415	T2NFK	JCTCFK	CDAXFK	R390K	SAR 344-392	STUP + AAR354
ANTWERP	DALLAS	36,85	1,451	9,78	0,385	T2NFK	JCTCFK	CDAXFK	R400K	SAR 344-393	VZ + AAR360
MADRID	LAPWING	38,20	1,504	9,78	0,385	T2NFK	JCTCFK	CDAXFK	R400K	SAR 344-395	VZ + AAR375
-	FALCON	39,24	1,545	10,54	0,415	T3NFK	JCTCFK	CDAXFK	R480K	SAR 344-396	VZ + AAR385
ATHENS	BLUEBIRD	44,75	1,762	10,54	0,415	T3NFK	JCTCFK	CDAXFK	R480K	SAR 393-448	VZ + AAR440

Dervaux has also developed a full range of product for ULS & AZR conductors.

Services

Our experts will provide you with support all throughout your projects and with effective and secure use for our product ranges.

Advice and assistance

We have specialist teams available throughout the world in case you need technical assistance, whether you need advice on a product. Specific information in terms of implementation or any question concerning the environment and conditions for using our solutions in your networks.



Recommendations on the products for your installation projects

In each of our areas of activity our specialists can advise you on the technical solutions best suited to your technical requirements.

- Network configurations
- Standards for premises installations
- Climatic constraints
- Geographical constraints



sicame | ACADEMY

Sicame's training expertise at your service

Discover our expertise and our training programs at Sicame Academy for ever-increasing quality, reliability and sustainability of power networks throughout the world.

Sicame Group has created a network of training centers for its customers: **Sicame academy**, which offers in France and around the world, theoretical and practical training for acquiring the skills necessary for mastering the implementation of products as well as the safety procedures necessary for the work.

In France, the Group is affiliated as a training body (Affiliation no. for France: 74 19 00593 19) and certification body. All of the training modules can be carried out at our different premises or at your site. These modules can cover general knowledge, live-line work or dead-line work.



Advanced conductor accessories ACCC InfoCore system

The ACCC InfoCore™ system was created by CTC Global to offer a novel way of verifying a successful installation by field crews.

- The ACCC InfoCore™ system makes use of special fibres
- ACCC® Conductor to enable inspection in a quick and efficient manner.
- This system lowers the risk
- Aware that accidents can occur even with the best tools, equipment, and working conditions.
- The InfoCore system can verify the conductor's integrity in just a few minutes
- Reliable data-capture and recording methodology.
- Utility companies and contractors can install equipment with more assurance

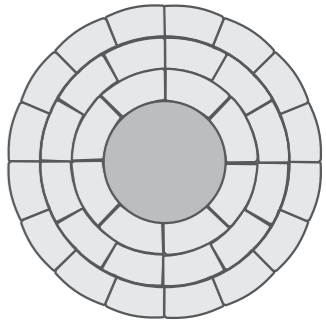

Advanced end fittings

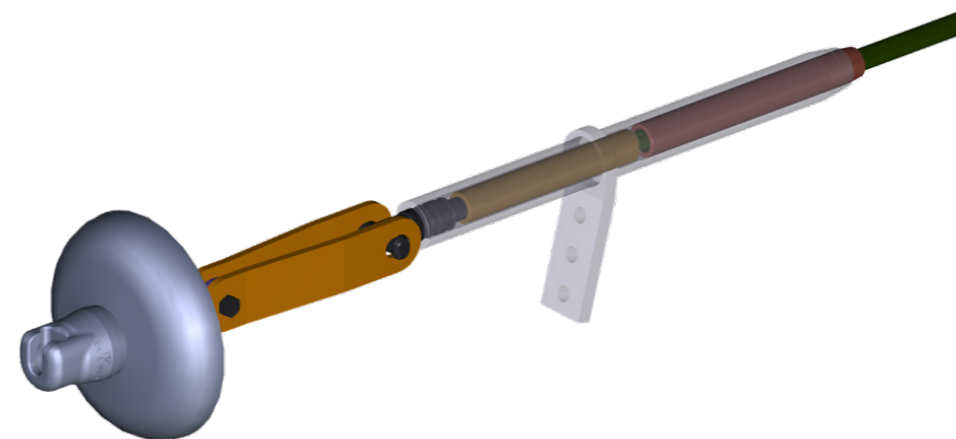

5400 J.A. Bombardier
 Saint-Hubert, Québec - J3Z 1G8, Canada
 Phone: +1 450 679 7778
 E-mail: info@sicamena.com
 Website: sicame-energie.com

sicame
 ENERGIE

Dervaux
 Sicame Group

Z.I. Le Bec - Allée Ampère - B.P. 49 - 42501 Le Chambon-Feugerolles, France
 Phone: +33 (0)4 77 40 17 40
 E-mail: info@dervaux.fr

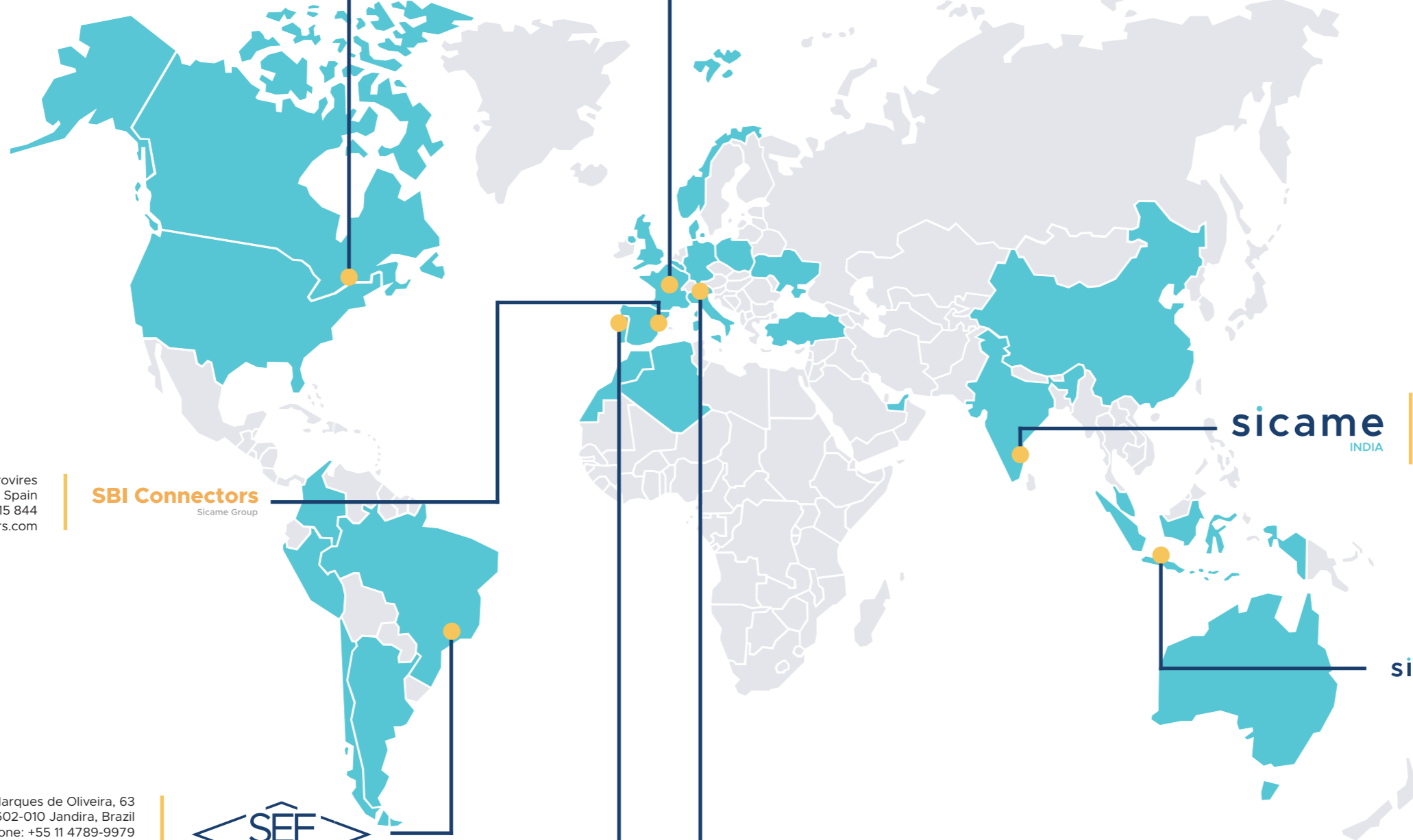

Carrer Albert Einstein, 5-7 Pol. Ind. Sesrovires
 08635 Sant Esteve Sesrovires, Barcelona, Spain
 Phone: +34 937 715 844
 Website: sbiconnectors.com

SBI Connectors
 Sicame Group

sicame
 INDIA

S.No.473/1 - No.96, Sirkundram Road Village Chengalpet Taluk,
 Kancheepuram District - 603 108, India
 Phone: +91 44 37270300
 E-mail: info@sicame.in
 Website: sicame.in



Salvi Eletro Fittings - Rua Pureza Marques de Oliveira, 63
 Núcleo Micro Industrial Pres. Wilson - 06602-010 Jandira, Brazil
 Phone: +55 11 4789-9979
 E-mail: eletro@eletrofittings.com.br
 Website: salvibr.com.br

SEF
 Sicame Group

sicamindo

CCM Industrial Estate Kav F-1 No.7
 Jl. Raya Serang KM 28,5 Balaraja,
 Tangerang 15610, Banten - Indonesia
 Phone: (+62-21) 595 4861-62
 E-mail: marketing@sicamindo.com
 Website: sicamindo.com

Rua Estrada da Rainha nº 340
 4410-030 Serzedo Vila Nova de Gaia, Portugal
 Phone: +351 22 730 0240
 E-mail: skelt@skelt.pt
 Website: skelt.pt

skelt
 Sicame Group

SALVI
 Sicame Group

Via G. Durando, 38 - 20158 Milano, Italia
 E-mail: salvi@salvi.eu
 Website: salvi.eu





Sicame Group

+33 (0)5 55 73 89 00
1 boulevard Marius Vivier Merle, 69003 Lyon, France

 [sicame-group.com](https://www.sicame-group.com)